

VVZ 210 T (250, 310)

TECHNOLOGY FOR A SUSTAINABLE TOMORROW

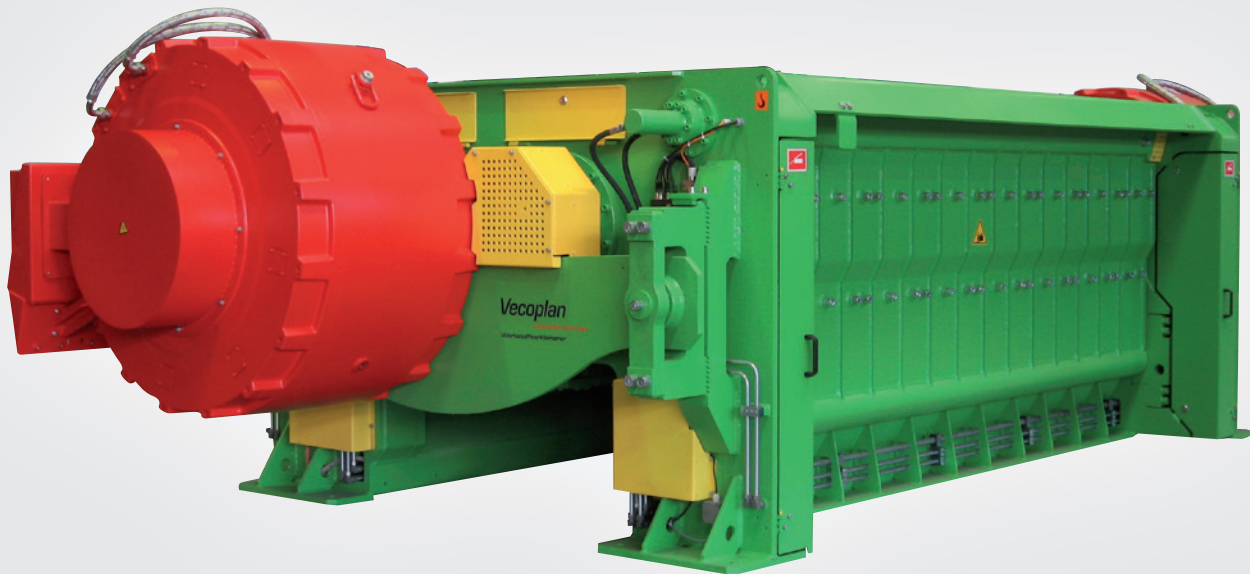

Shredding



APPLICATION

For domestic, bulky and commercial waste, scrap wood and production waste.

HURRICANE
...die nächste Generation der Vorzerkleinerung

Vecoplan[®]

VVZ 210 T (250, 310)

TECHNOLOGY FOR A SUSTAINABLE TOMORROW



Shredding

Front view

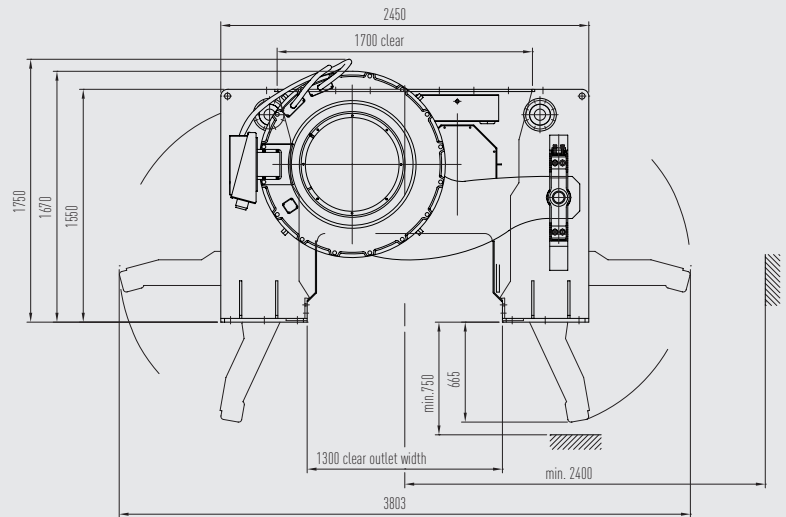

Side view

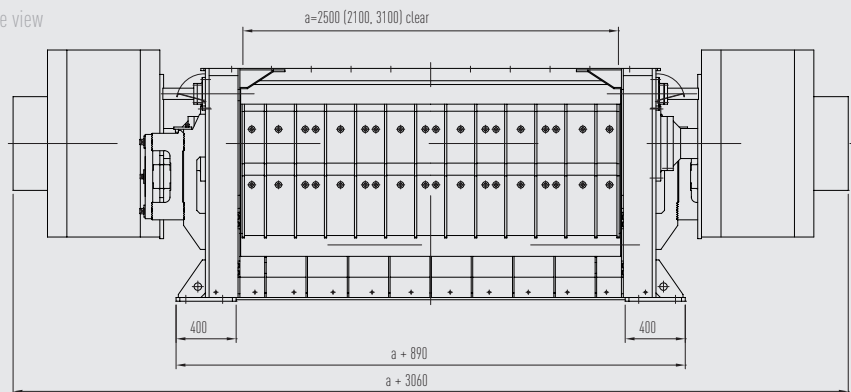

Image shows version with special equipment

DETAILS

		VVZ 210 T	VVZ 250 T	VVZ 310 T
Infeed opening	mm	1700 x 2100	1700 x 2500	1700 x 3100
Rotor dimensions	mm	2 x 720 x 2100	2 x 720 x 2500	2 x 720 x 3100
Number of tools	qty	2 x 10 (15,20)	2 x 12 (18,24)	2 x 15 (22)
Rotor speed	rpm	0 - 85	0 - 85	0 - 85
Motor power	kW	2 x 155	2 x 155	2 x 155
Capacity	t/h	10 - 55*	15 - 90*	20 - 100*
Weight approx.	t	23	26	30
Overall dimensions	cm	516 x 245 x 175	556 x 245 x 175	616 x 245 x 175

Subject to technical changes without notice / Dated: 05/2010

* Depending on input material and screen perforation