

VNZ 200 XL – 250 XL

TECHNOLOGY FOR A SUSTAINABLE TOMORROW

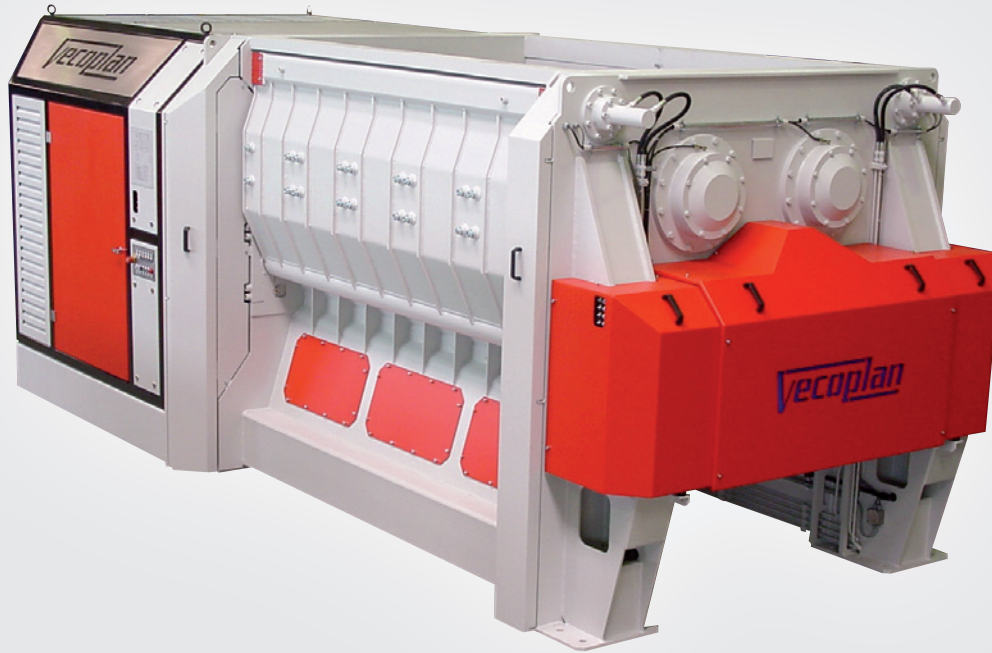

Shredding



APPLICATION

For difficult materials with foreign-parts and tramp metal such as pallets, boxes, cable drums, demolition timber, pieces of furniture, chipboard, domestic or commercial waste and refuse derived fuels.

Vecoplan[®]

VNZ 200 XL – 250 XL

TECHNOLOGY FOR A SUSTAINABLE TOMORROW



Shredding

Front view

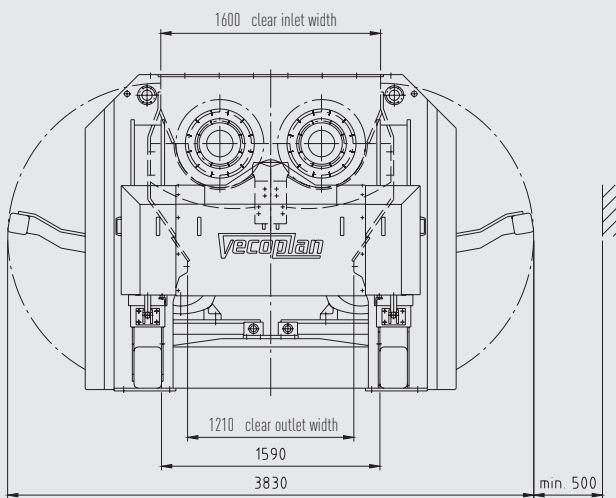

Side view

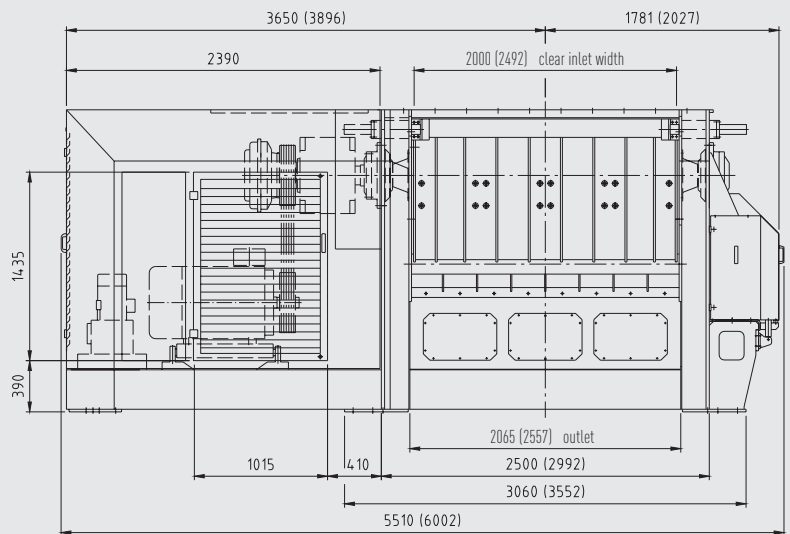

DETAILS

		VNZ 200 XL	VNZ 250 XL
Infeed opening	mm	2000 x 1600	2492 x 1600
Rotor dimensions	mm	2 x 640 x 2000	2 x 640 x 2492
Number of tools	qty	2 x 48 / 62	2 x 60 / 76
Rotor speed	rpm	165	165
Motor power	kW	2 x 132 / 2 x 160	2 x 160 / 2 x 200
Capacity	t/h	5 - 25*	6 - 35*
Weight approx.	t	22,5	26,5
Overall dimensions	cm	551 x 278 x 230	600 x 278 x 230

Subject to technical changes without notice / Dated: 05/2010

* Depending on input material and screen perforation