

VECOBELT

TECHNOLOGY FOR A SUSTAINABLE TOMORROW



Conveying



APPLICATION

The pipe belt conveyor "VecoBelt" is ideal for conveying bulk materials over long distances either horizontally or on a slight incline. The material being transported glides on a cushion of air in a closed steel tube.

Vecoplan[®]

VECOBELT

TECHNOLOGY FOR A SUSTAINABLE TOMORROW



Conveying

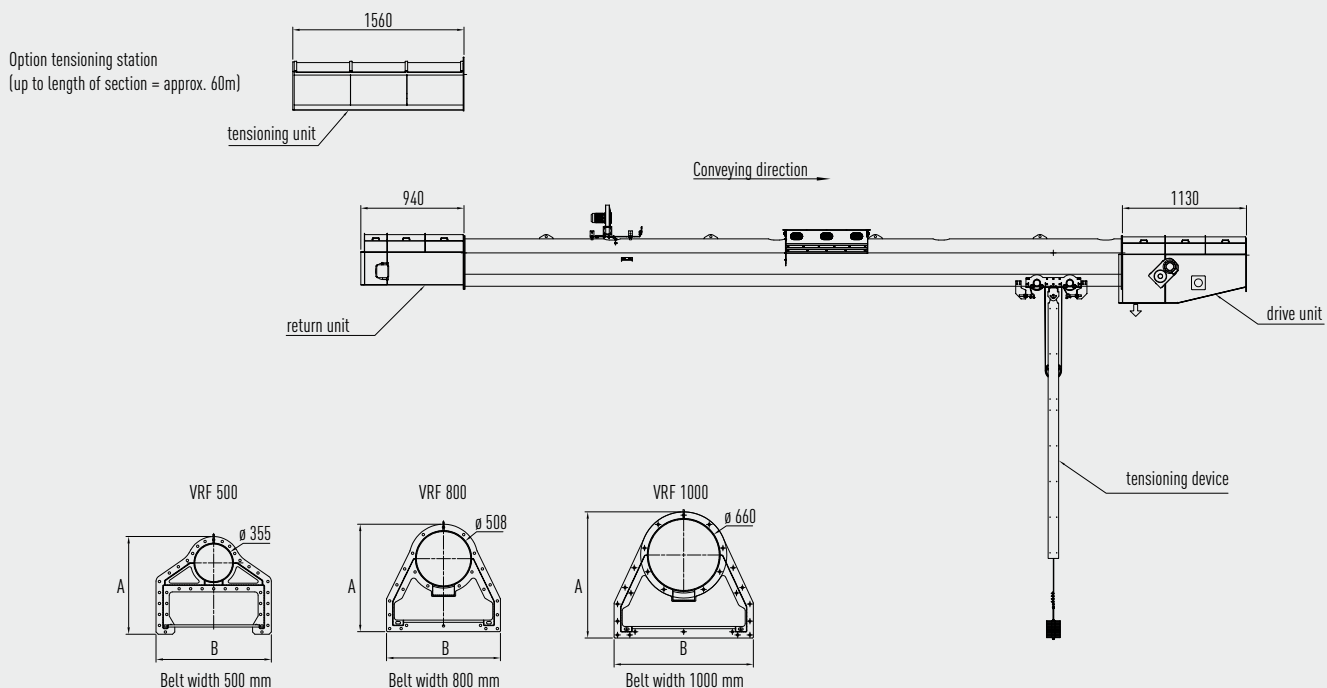

DETAILS

		VRF 500	VRF 800	VRF 1000
Belt width	mm	500	800	1000
Permanent weight (incl. belt & rolls)	kg/lfm	220	300	390
Pipe diameter	mm	355	508	660
Conveying capacity	m ³ /h*	360	720	1500
Height A	mm	890	979	1150
Width B	mm	1050	1038	1270

Subject to technical changes without notice / Detailed dimension drawings and load data available on request / Dated: 01/2013

* at conveying speed of 150 m/min. and horizontal course