

VTH 8

TECHNOLOGY FOR A SUSTAINABLE TOMORROW



Shredding



APPLICATION

For the production of high quality wood chips made from short or long pieces of waste wood from the timber sizing and wood processing industry.

Vecoplan[®]

VTH 8

TECHNOLOGY FOR A SUSTAINABLE TOMORROW



Shredding

Plan view

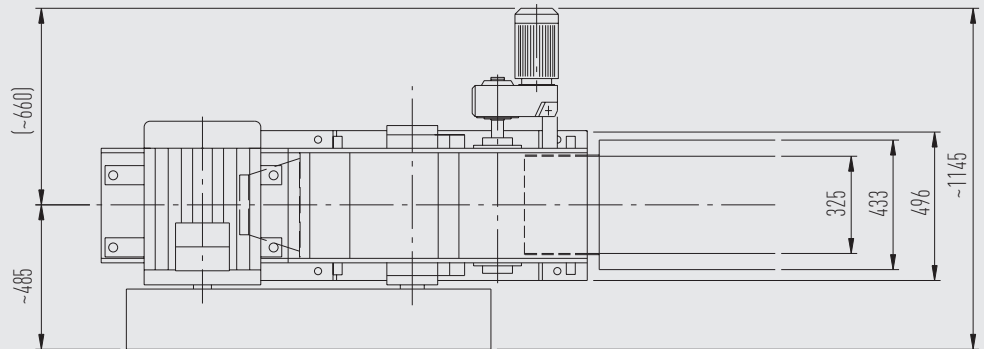

Side view

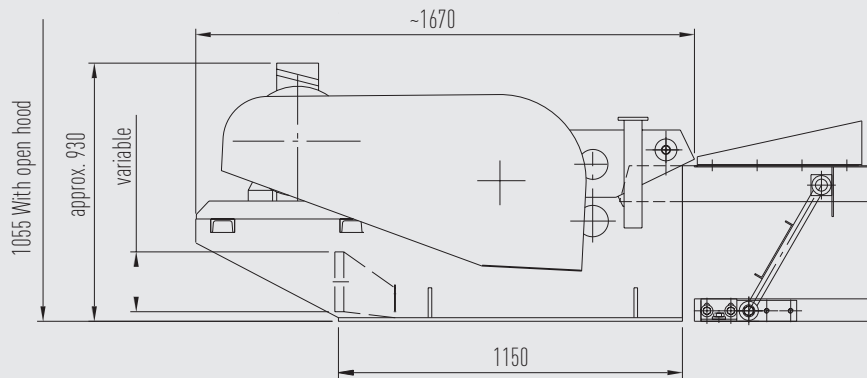

DETAILS

		VTH 35/8/2
Infeed opening	mm	325 x 80
Infeed rollers	qty	2
Rotor diameter	mm	300
Number of tools	qty	2
Rotor speed	rpm	670 - 2100
Chipping length	mm	3 - 30 *
Required motor power	kW	22 - 30
Max. capacity	stere/h	2 *
Weight approx.	kgs	890

Subject to technical changes without notice / Dated: 09/2010

* Depending on input material and chipping length

Also available with cutting crown rotor.