

# VTH 15

TECHNOLOGY FOR A SUSTAINABLE TOMORROW

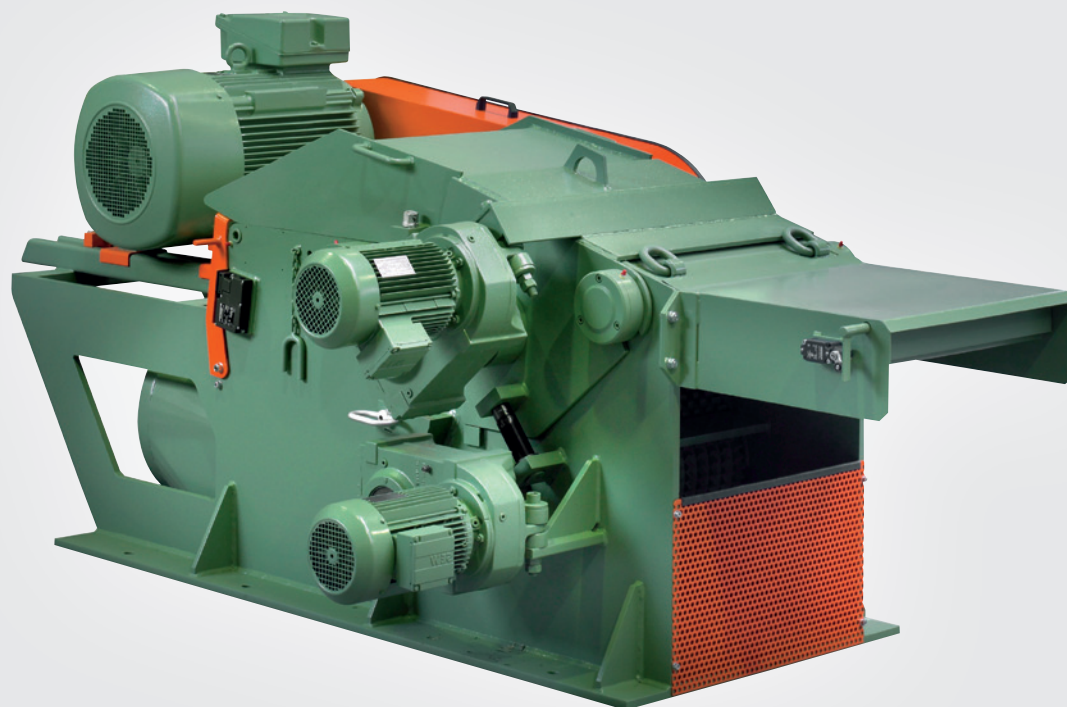

Shredding



## APPLICATION

For the production of high quality wood chips made from short or long pieces of waste wood from the timber sizing and wood processing industry.

**Vecoplan**<sup>®</sup>

# VTH 15

TECHNOLOGY FOR A SUSTAINABLE TOMORROW



Shredding

Plan view

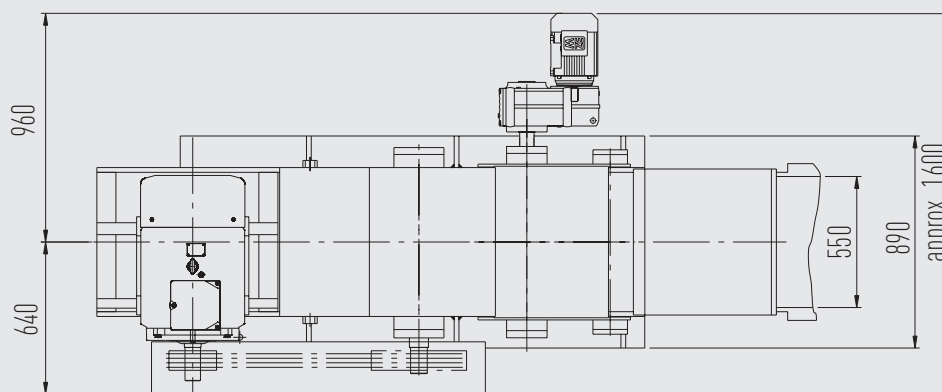

Side view

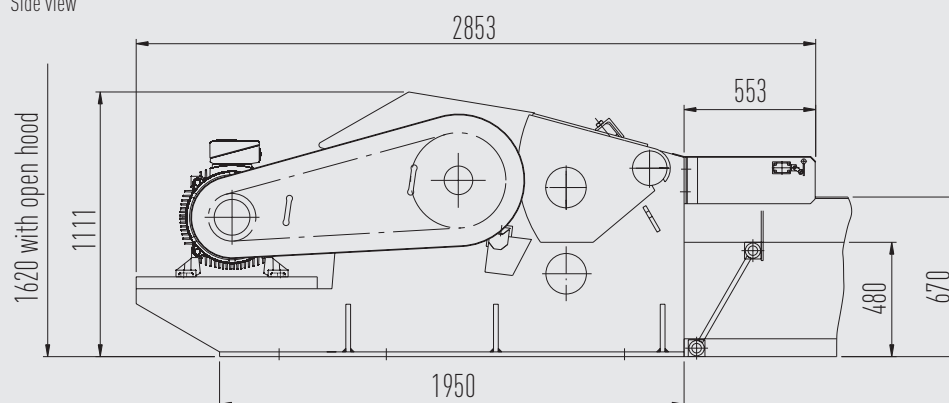

## DETAILS

|                      |         | VTH 55/15/2 |
|----------------------|---------|-------------|
| Infeed opening       | mm      | 550 x 150   |
| Infeed rollers       | qty     | 2           |
| Rotor diameter       | mm      | 500         |
| Number of tools      | qty     | 2 - 4       |
| Rotor speed          | rpm     | 600 - 980   |
| Chipping length      | mm      | 3 - 30 *    |
| Required motor power | kW      | 37 - 75     |
| Max. capacity        | stere/h | 16 *        |
| Weight approx.       | kgs     | 3200        |

Subject to technical changes without notice / Dated: 09/2010

\* Depending on input material and chipping length

Also available with cutting crown rotor.