

VTH 12 U

TECHNOLOGY FOR A SUSTAINABLE TOMORROW

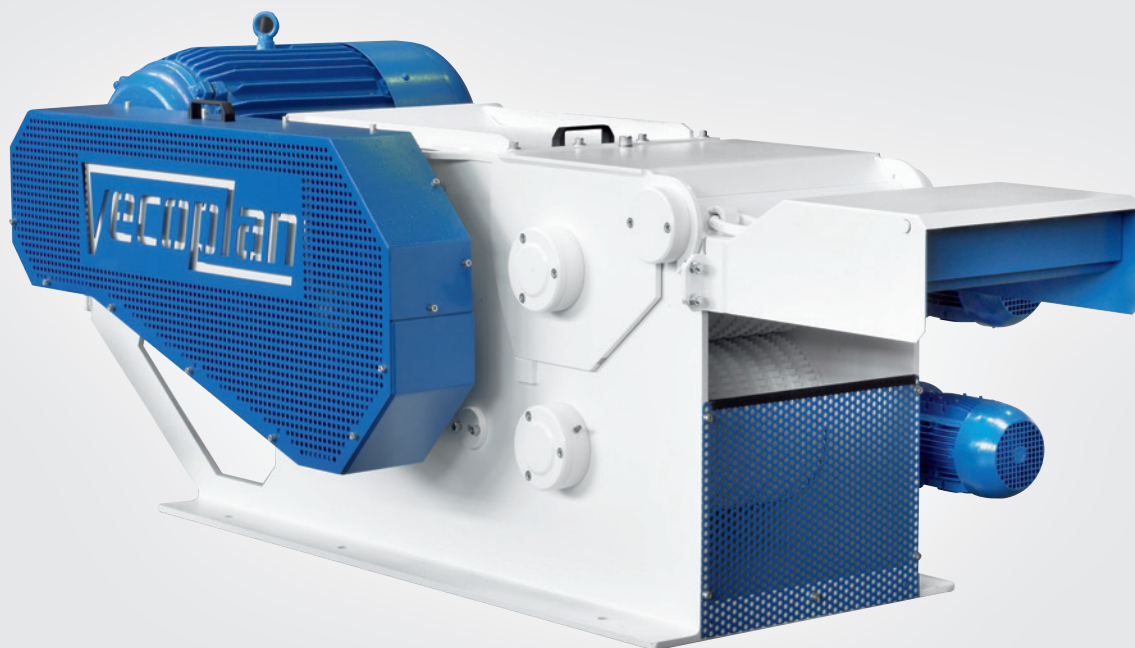

Shredding



APPLICATION

Extrusion profiles, plastic strips, soft woods, hard woods and all kinds of timber waste that occur in typical carpenter's workshops and joineries. Especially for long pieces of materials.

Vecoplan[®]

VTH 12 U

TECHNOLOGY FOR A SUSTAINABLE TOMORROW



Shredding

Example

VTH 45/12/2 U

Front view

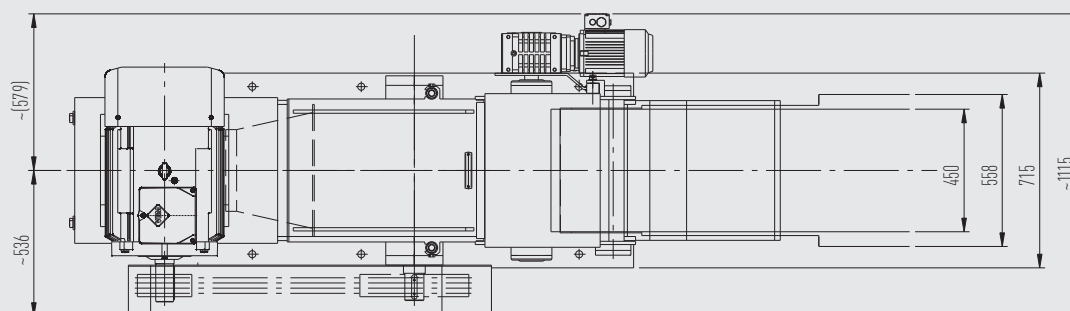

Side view

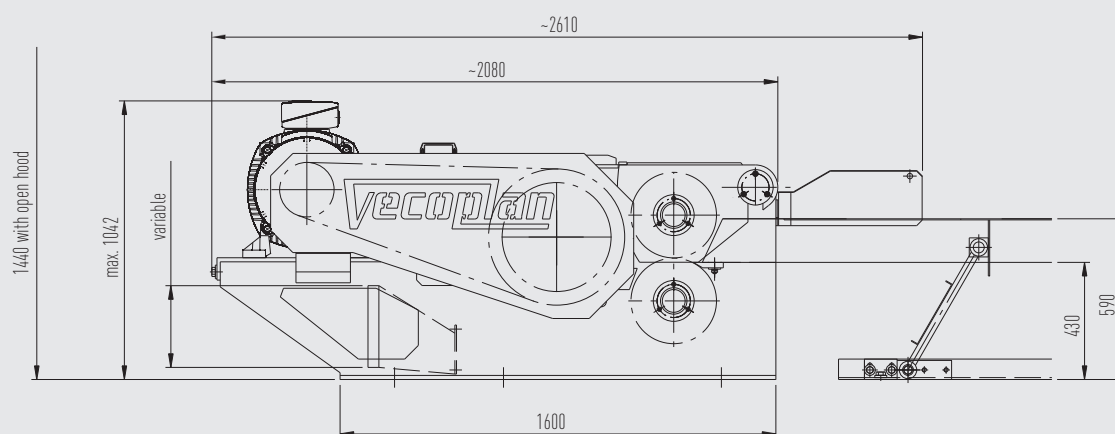

DETAILS

		VTH 45/12/2	VTH 65/12/2	VTH 85/12/2
Infeed opening	mm	450 x 120	650 x 120	850 x 120
Infeed rollers	qty	2	2	2
Rotor diameter	mm	400	400	400
Number of tools	qty	24	34	44
Rotor speed	rpm	500	500	500
Required motor power	kW	30 - 37	30 - 45	45 - 75
Max. capacity	stere/h	4 *	6 *	7 *
Weight approx.	kgs	1900	2250	2600

Subject to technical changes without notice / Dated 09/2010

Version only available with cutting crown rotor.

* Depending on input material and screen perforation