

# VTH 20

TECHNOLOGY FOR A SUSTAINABLE TOMORROW

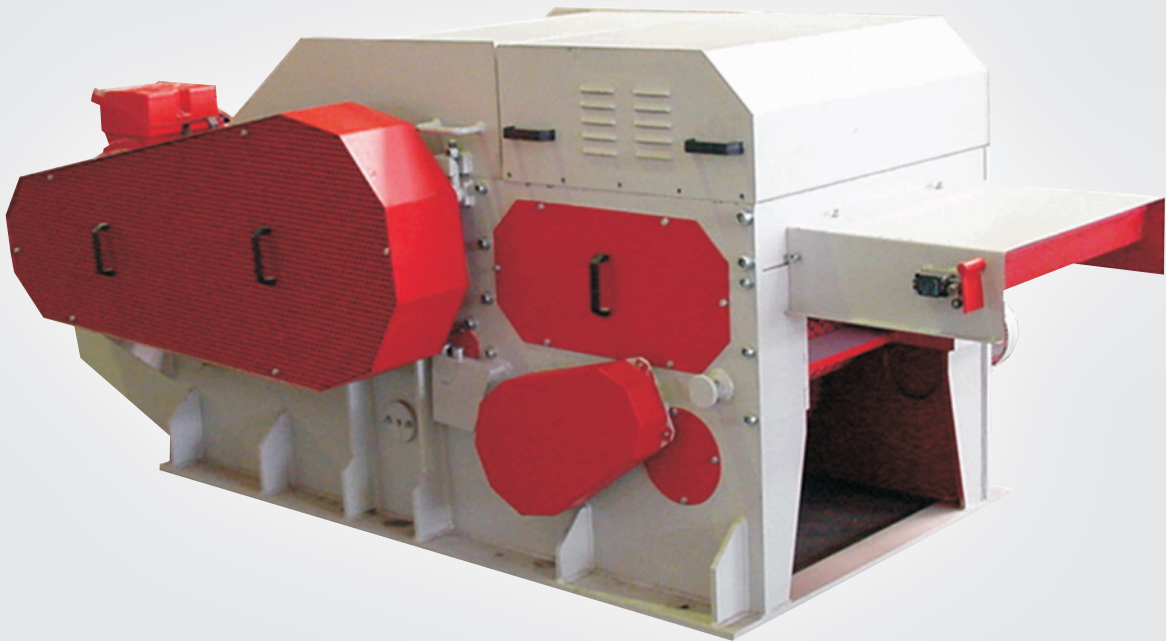

Shredding



## APPLICATION

Our drum chippers produce top quality wood chips from slabs, edgings, round timber and all kinds of wood. This drum chipper is primarily used in sawmills, furniture factories and planing mills.

**Vecoplan**<sup>®</sup>

# VTH 20

TECHNOLOGY FOR A SUSTAINABLE TOMORROW



Shredding

Example

## VTH 55/20/3

Front view

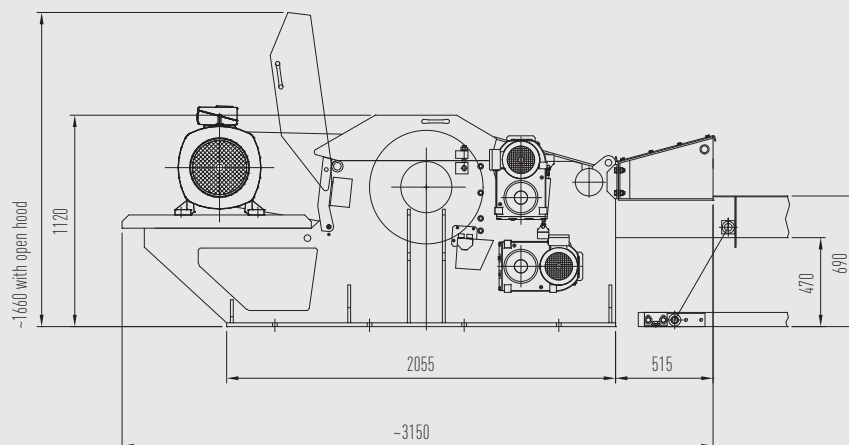

Side view

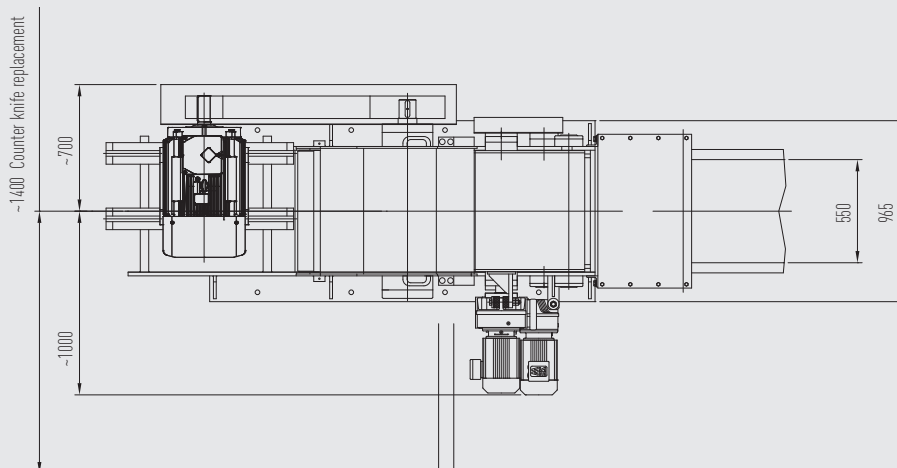

## DETAILS

		VTH 55/20/3	VTH 65/20/3	VTH 85/20/3
Infeed opening	mm	550 x 200	650 x 200	850 x 200
Infeed rollers	qty	3	3	3
Rotor diameter	mm	600	600	600
Number of tools	qty	2-4	2-4	2-4
Rotor speed	rpm	730 - 930	730 - 930	730 - 930
Chipping length	mm	3 - 30 *	3 - 30 *	3 - 30 *
Required motor power	kW	45 - 75	55 - 90	55 - 90
Max. capacity	stere/h	23 *	25 *	30 *
Weight approx.	kgs	3500	4200	5700

Subject to technical changes without notice / Dated 09/2010

\* Depending on input material and chipping length