

DISC SEPARATOR

TECHNOLOGY FOR A SUSTAINABLE TOMORROW

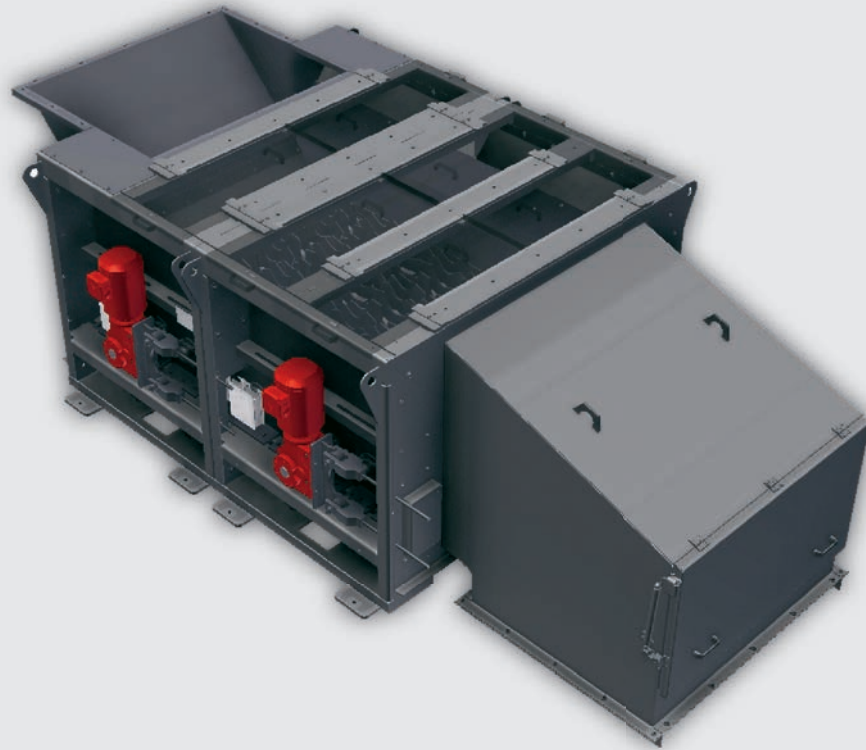

Screening



APPLICATION

The disc separator is especially suitable for the separation of overlength parts out of sorted material like dry stabilate, bark, green cut, wood, etc. The flexibly mounted discs reduce jamming of the conveying material. Customized length due to segment construction.

Vecoplan[®]

DISC SEPARATOR

TECHNOLOGY FOR A SUSTAINABLE TOMORROW



Screening

Front view

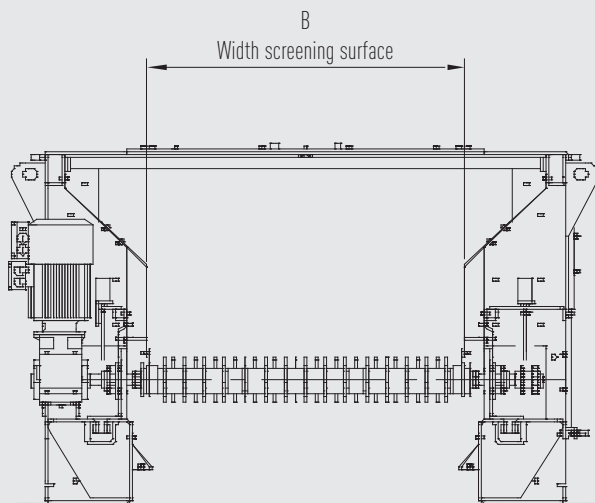

Side view

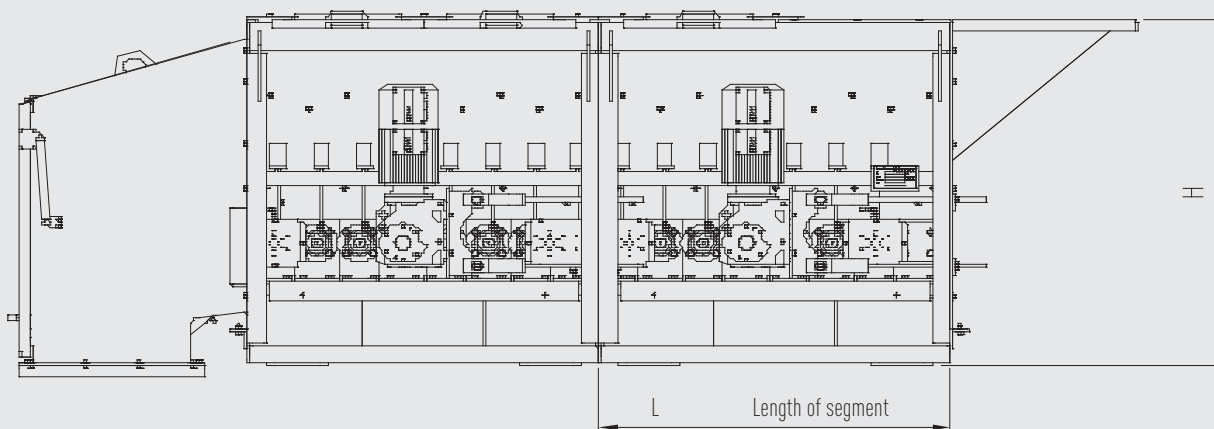

DETAILS

		Standard design	Standard design	Heavy design	Heavy design
Length of segment	mm	1,150	1,150	1,600	1,600
Width screening surface	mm	1,000	1,250	1,250	1,600
Height of screen	mm	1,385	1,385	1,350	1,350
Screening capacity	m ³ /h	depends on material, screen size and number of segments			
Cross cut from – to	mm	30 - 500	30 - 500	50 - 300	50 - 300
Motor power per segment	kW	3	3	7.5	7.5

Optionally: Central lubrication system for bearing and chain drive

Subject to technical changes without notice / Detailed dimension drawings and load data available on request / Dated: 04/2012

* Depending on input material and screen perforation